

606

POWER AMPLIFIER

INSTRUCTION BOOK

Q U A D

INTRODUCTION	2
GUARANTEE	2
SERVICE	2
ACCESSORIES SUPPLIED	3
INSTALLATION	3
Checking the AC Power Supply	3
Connecting to the AC Power Supply	4
AC Power Out	4
Positioning the Amplifier	4
Connection to the Control Unit	4
Loudspeaker Connection	5
SWITCHING ON AND OFF	6
AMPLIFIER PROTECTION	6
LOUDSPEAKER PROTECTION	6
QUAD ELECTROSTATIC LOUDSPEAKERS	6
LOUDSPEAKER PHASING	6
HEADPHONES	6
MAINTENANCE	6
FRONT AND REAR VIEW	7
Connecting Sockets	7
SPECIFICATION	8
Power Output Graph	inside back cover
ACCESSORIES	inside back cover

Quad high fidelity equipment is designed to reproduce music at realistic levels, but there is a world of difference between the sound pressure levels produced by a string quartet and a heavy metal group.

Please be aware that very high sound pressure levels can cause permanent hearing damage, but such levels will also cause severe annoyance to neighbours.

INTRODUCTION

The Quad 606 is a high quality stereo power amplifier primarily intended for use in very high quality sound reproducing systems. It will normally be used in conjunction with a Quad control unit though other signal sources can be used.

The 606 uses a current dumping output circuit, a Quad invention which eliminates many of the problems associated with transistor amplifiers and is covered by patents in several countries. In a current dumping amplifier there is in effect both a low power very high quality amplifier and a high power heavy duty amplifier. The low power amplifier controls the loudspeakers at all times calling on the high power amplifier to provide most of the muscle. The low power amplifier is so arranged - it carries an error signal - that provided the larger power transistors (the current dumpers) get within the target area of the required output current it will fill in the remainder accurately and completely. The reproduced quality is **solely** dependent on the small amplifier which because of its low power can be made very good indeed.

Problems of crossover distortion, quiescent current adjustment, thermal tracking and transistor matching all disappear. There are no internal adjustments or alignments and the choice of power transistor types is less restrictive. The performance of the Quad 606 amplifier is as accurate as it is possible to achieve by careful design, selection of components and rigorous test procedures.

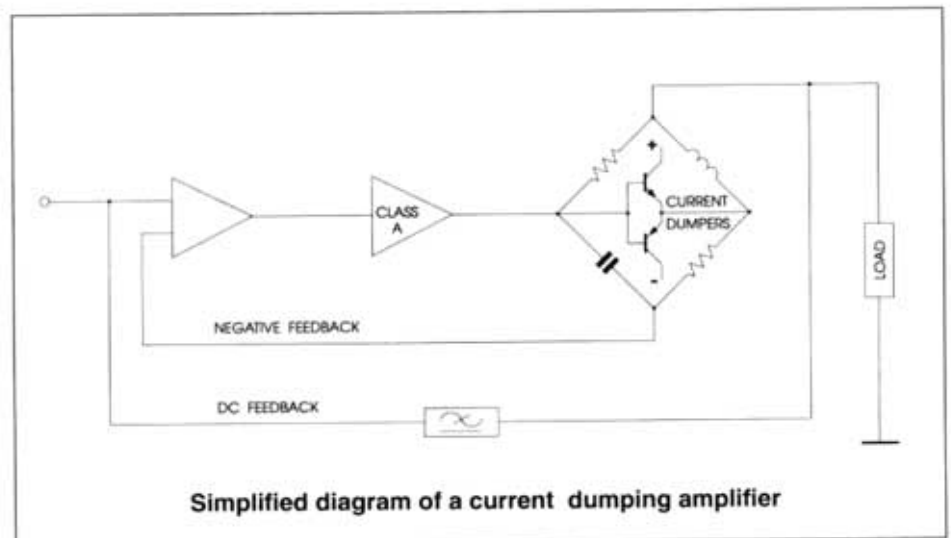

Simplified diagram of a current dumping amplifier

GUARANTEE

The Quad 606 amplifier is guaranteed for twelve months from the date of purchase. Within this period we undertake to supply replacement parts free of charge provided that the failure was not caused by misuse, accident or negligence. Return freight and third party labour costs are not covered unless by local agreement.

Within the UK this guarantee does not limit your statutory rights. A separate guarantee card is not supplied and your guarantee begins on the day of purchase.

SERVICE

If the amplifier requires service it should be returned to the supplier, the distributor for the country of purchase or Quad Electroacoustics Ltd.

Please enclose a brief note giving your name and address and the reason for returning it.

Quad offer a same day service from Monday to Friday except for Bank holidays. Please contact us to make an appointment.

How to Find us

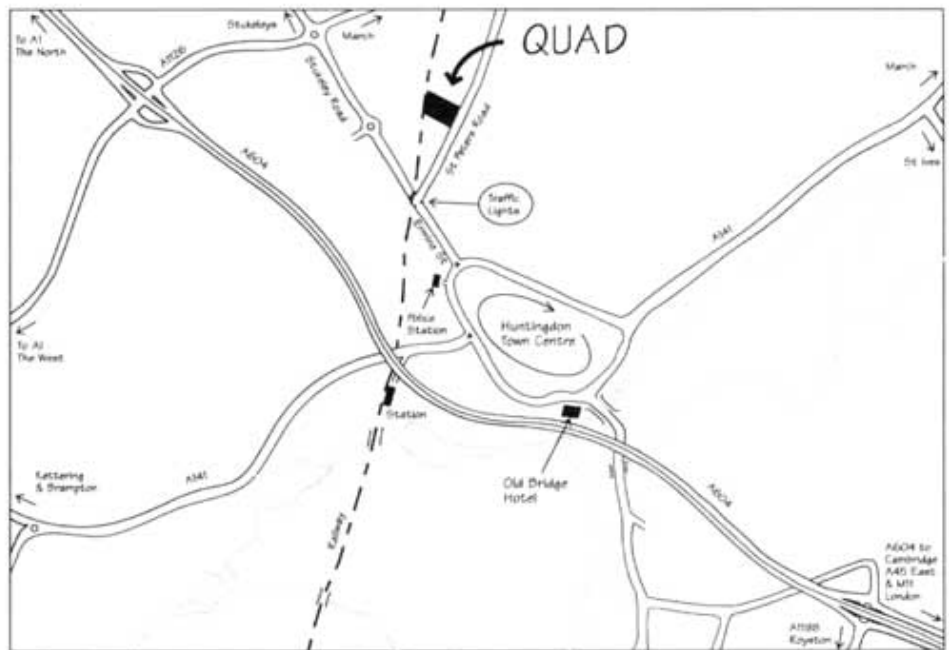

Important

Retain the original carton and internal packing in case the amplifier has to be returned for service.

ACCESSORIES SUPPLIED

AC supply lead 1m long	Type No. QSPES1B
Signal lead 1m long	Type No. QP2P21A
Two 4mm loudspeaker plugs (red)	Type No. PP60912
Two 4mm loudspeaker plugs (black)	Type No. PP60920

INSTALLATION

The Quad 606 amplifier has no controls other than an on/off switch (which is normally left on) and may be mounted out of sight in a cabinet or other convenient location. However, since its dimensions correspond with those of other Quad units they can be stacked or stood side by side as required. If used close to a record deck or other equipment susceptible to hum it may be necessary to increase the spacing between them.

The amplifier will run warm, the actual temperature depending on the power output. A resettable current trip will automatically switch the amplifier off under gross overload or short circuit output etc. The fins of the heatsink should be kept clear of obstruction to allow adequate ventilation in normal use.

See **Amplifier Protection** - page 6.

Checking the AC Power Supply

The 606 amplifier is supplied in five versions suitable for connection to either 240V, 220V, 120V, 110V and 100V AC power supplies. Before Connecting the amplifier to the AC supply check that you have the correct version - the operating voltage is clearly marked on the back. No damage will be caused if the amplifier is connected to a lower voltage than marked but the maximum output power will be lower than specified.

The Quad 606 can be converted from 240V to 120V and from 220V to 110V or vice versa by changing two soldered wire links on the power supply board, as well as replacing the current trip and the mains power input fuse. The rating label should also be changed.

Before connecting to the AC power supply check that the voltage range marked on the back corresponds with that of the supply.

Connecting to the AC Power Supply

The 606 amplifier is supplied with a 1m long AC supply lead fitted with standard 3-pin Euro connectors for connection between the amplifier **AC power in** and the **AC power out** socket fitted on the back of current Quad equipment. For connection to other equipment, or direct to the mains supply, your dealer can supply a longer lead to which a suitable plug should be fitted, as explained below:-

WARNING: THIS APPARATUS MUST BE EARTHED

IMPORTANT - Fitting a mains plug.

The wires in the mains lead are coloured:

Brown = Live Blue = Neutral Green/Yellow = Earth

The **Brown** wire must be connected to the terminal marked **L** or coloured **Red**. The **Blue** wire must be connected to the terminal marked **N** or coloured **Black**. The **Green/Yellow** wire must be connected to the terminal marked **E** or coloured **Green** or **Green/Yellow**.

Note

When a 13A plug is used this should be fitted with 13A fuse, or if another type of plug is used, by a 13A fuse either in the plug or adaptor, or at the distribution board. If in doubt consult a qualified electrician.

AC power Out

The 606 amplifier is fitted with an unswitched **AC power out** socket for feeding other units in the system. The Quad CD player, FM tuner and other Quad units are provided with the appropriate interconnecting cables.



Positioning the Amplifier

The 606 amplifier can be positioned free-standing or stacked with other components. Never place it in persistent direct sunlight or near any heat source.

Connection to the Control Unit

At the back of the 606 you will find the **audio input** sockets for the connecting lead from the control unit. Insert the White plug of the audio connecting lead to the L socket (white = left channel) and the Red plug to the R socket (red = right channel).

Insert both the plugs, at the other end of the lead, into the **audio output** sockets of your Quad control unit.

Make sure that the plugs are pushed fully in, at both ends, to ensure good connections. Poor connection will cause hum.

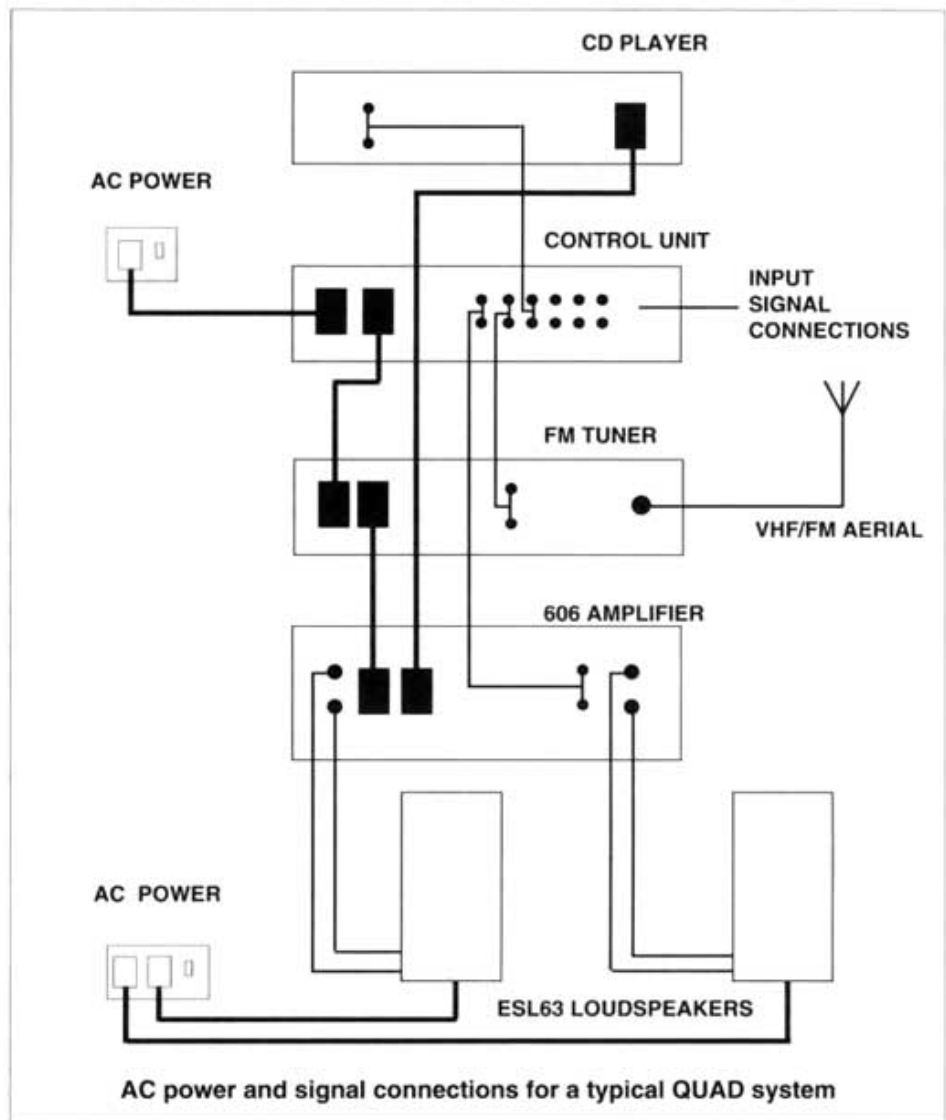

Loudspeaker Connection

The Quad 606 is fitted with standard **4 mm sockets/binding posts**. Two each of red and black plugs are supplied. The 606 is unconditionally stable and can be used with any type of loudspeaker cable. For optimum performance it is necessary to ensure that the resistance of the cable is small relative to the loudspeaker impedance.

Each loudspeaker should be connected to the appropriate output sockets so that the two pairs of wires are connected in the same way, to ensure that the speakers are correctly phased. The output terminals are colour coded to facilitate this.

Should there be any doubt the phasing can be checked experimentally. See **Loudspeaker Phasing** - page 6.

In special cases where the loudspeakers also require an energising supply the instructions for the loudspeakers must be followed.

Each loudspeaker should be capable of handling the full output of the amplifier. The outputs must not be connected in parallel or in series to produce a single channel amplifier.

Note

Take care if heavier than normal grade loudspeaker cables are used as these can place undue strain on the output sockets.

SWITCHING ON AND OFF

Switching On - Press the **on/off switch**. This has a rocker action, press the bottom to switch the amplifier on and the top to switch it off. Leave the amplifier switched on. In normal use it will be controlled via the **on/off** switch on the Quad control unit.

AMPLIFIER PROTECTION

The 606 amplifier is protected by a resettable current trip which interrupts the incoming AC Power supply if the amplifier is grossly overloaded for a period of time. To restore operation simply press the red reset button on the back panel. It is thus fully protected against gross overload, short-circuited output etc, but not necessarily against seriously inadequate ventilation.

LOUDSPEAKER PROTECTION

The loudspeaker manufacturer will usually state a maximum recommended amplifier power output, but as the maximum safe power for most loudspeakers is time and frequency dependent it is difficult to define it precisely for a musical signal. Some manufacturers will permit their loudspeakers to be used with amplifiers exceeding the quoted handling provided certain precautions are observed. This can sometimes be an advantage in enabling short duration peaks to be handled without overload. The advice of the loudspeaker manufacturer should always be obtained if in any doubt.

QUAD ELECTROSTATIC LOUSPEAKERS

The 606 amplifier is fully compatible with the Quad ESL63 loudspeaker. It should not be used with the earlier model ESL which could be damaged by signal peaks unless a protection circuit is fitted inside each loudspeaker - please contact Quad Electroacoustics Ltd for details.

LOUDSPEAKER PHASING

If there is any doubt about the way the loudspeakers are connected their phasing can easily be checked by playing a mono source when the sound should appear to emanate from a point midway between the two loudspeakers. If this is indefinite then the connections to one of the loudspeakers should be reversed. When correctly connected the loudspeakers will give a definite centre sound source with more full bodied tenor and bass registers.

HEADPHONES

Headphones will normally be used instead of loudspeakers and there are a number of suitable switch units available designed to enable the loudspeakers to be switched off when the headphones are plugged in. Most of these incorporate a simple attenuator circuit to permit operation at normal settings of the control unit volume control.

Electrostatic or other types of headphones requiring a high level input should be operated in accordance with the manufacturer's instructions.

MAINTENANCE

No routine maintenance is required. If necessary the case can be cleaned with a soft brush or, for more stubborn marks, a slightly moistened lint-free cloth. In this case remove the mains plug from the supply socket. Do not use cleaning agents, solvents or abrasives.

FRONT VIEW

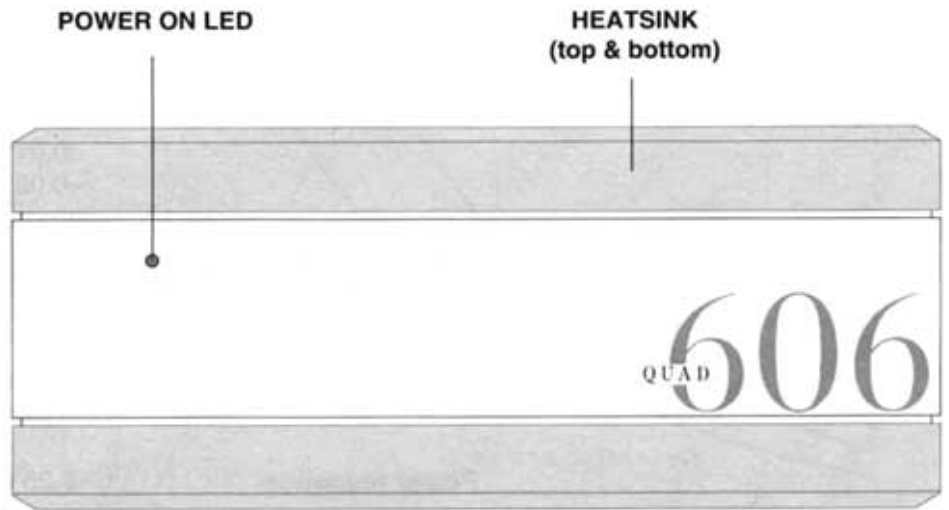

REAR VIEW

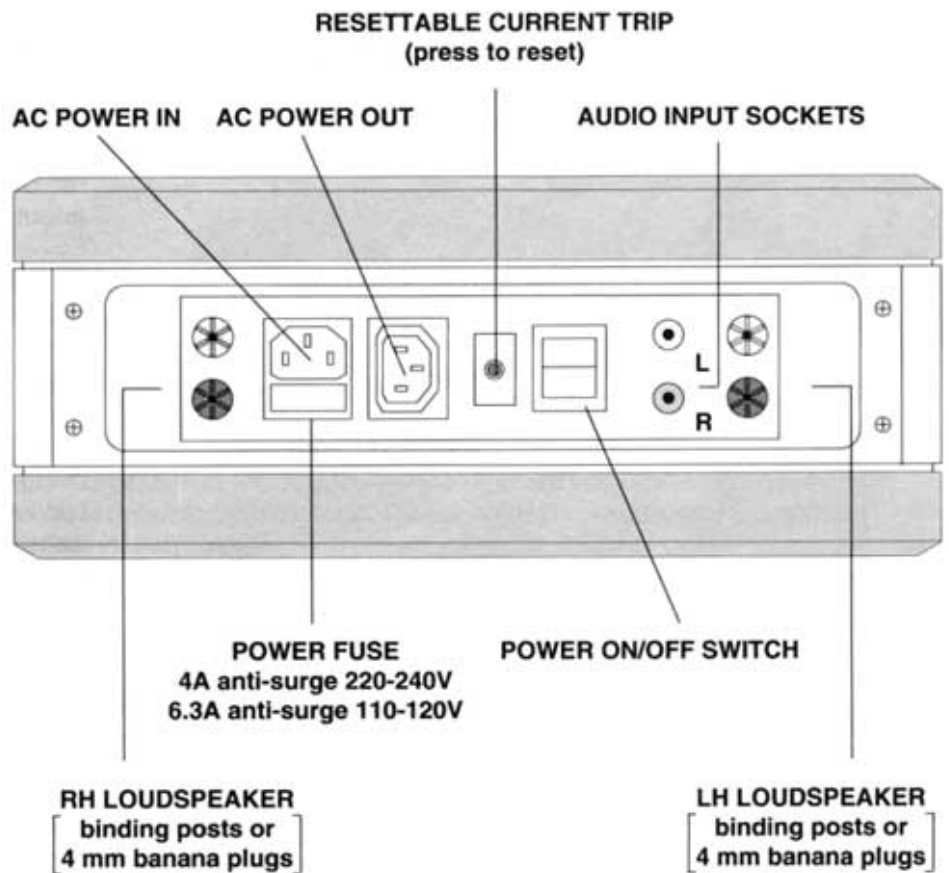

Connecting Sockets

- Audio Input:** Audio input connection from the audio output of your Quad control unit.
- Audio Output:** Audio output to the loudspeakers.
- AC Power In:** For the AC power supply input cable.
- AC Power Out:** An unswitched AC power outlet (4A max) for feeding power to other units in your Quad system.

SPECIFICATION

(Measurements made with 230V supply, one channel driven and apply to either channel.)

Power output:	140W into 8 Ω (see graph), 12A peak. 220W into 4 Ω (see graph), 12A peak.
Distortion (Dtot):	<0.01% at 20 Hz any level up to 130W. <0.01% at 1 kHz any level up to 130W. <0.03% at 20 kHz any level up to 130W. (Continuous sine wave into 8 Ω resistive load)
Output, internal impedance and DC offset:	1.5 μ H in series with 0.05 Ω . DC offset typically 7 mV.
Frequency response:	-0.25 dB at 20 Hz and 20 kHz, ref 1 kHz. -1.0 dB at 13 Hz and 40 kHz, ref 1 kHz.
Power response:	-0.25 dB at 20 Hz and 20 kHz, ref 1 kHz.
Input sensitivity:	500 mV for 140W into 8 Ω .
Input Impedance:	20 k Ω .
Input overload:	Instantaneous recovery up to +15 dB overload.
Crosstalk:	-100 dB at 100 Hz. -85 dB at 1 kHz. -65 dB at 10 kHz. (input loaded by 1 k Ω)
Hum and noise:	Unweighted -105dB ref 140W (15.7 kHz measurement bandwidth).
Stability:	Unconditionally stable with any load and input.
Mains voltage:	240V-120V, 220V-110V, and 100V AC. See rating details on back of unit (Requires changing two links on power board, or changing mains transformer, plus current trip and F1 AC power fuse).
Power consumption:	35-750W depending on output power level.
Protection; Fuse (F1):	AC power. 4A anti-surge for 220V and 240V. 6.3A anti-surge for 100V, 110V, and 120V.
Fuse (F2):	HT rail. 6.3A anti-surge, one per channel.
Current trip:	Resettable, 2A for 220 and 240V. 4A for 100V, 110V and 120V.
Dimensions:	Width 321 mm; height 140 mm; depth 238 mm (plus connectors) approx.
Weight:	12 kg approx.

The right is reserved to alter performance and specification as required.

This equipment complies with the radio interference requirements as laid down in EEC (European Economic Community) regulations.

Power Output Graph

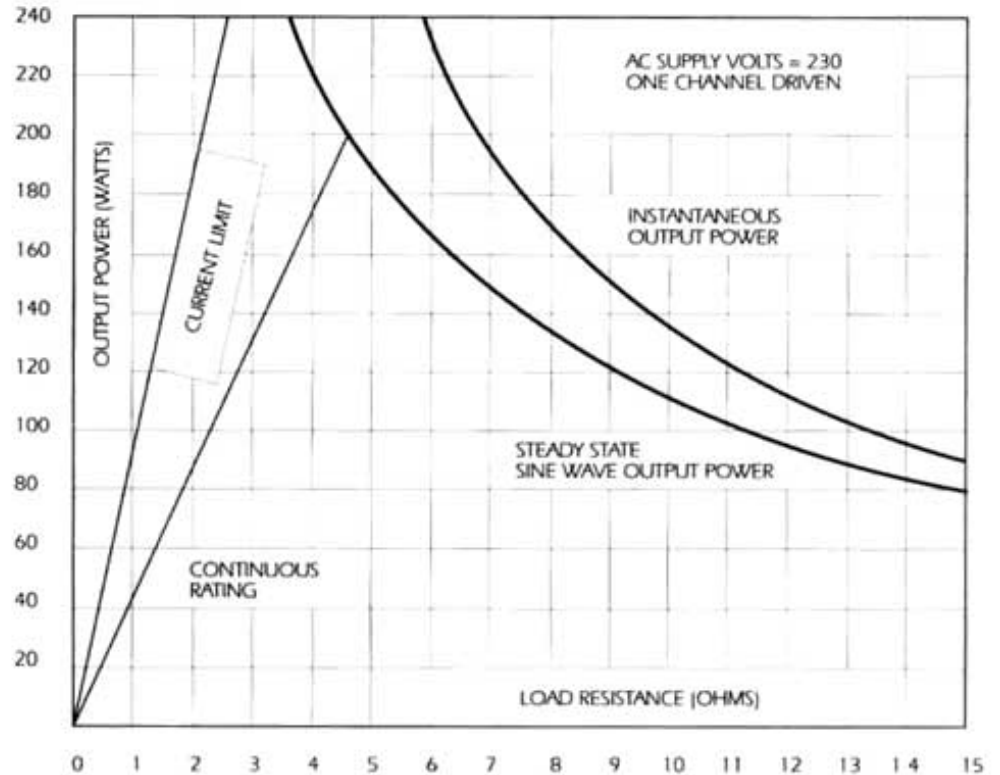

ACCESSORIES

Quad accessories are designed to match Quad equipment and to provide the best possible performance. Please contact your dealer or Quad direct for further information.

<i>Item</i>	<i>Order No</i>
Signal lead Phono (0.5m)	QP2P2SA
Signal lead Phono (1m)	QP2P21A
AC interconnect supply lead Euro/Euro (0.45m)	QSPES5B
AC interconnect supply lead Euro/Euro (1m)	QSPES1B
AC supply lead Euro/free end (2m)	QESOE2A
AC Euro output connector	PPR0413
Speaker plug 4 mm red	PP60912
Speaker plug 4 mm black	PP60920



Quad Electroacoustics Ltd Huntingdon PE18 7DB United Kingdom

Telephone:0480 52561 Fax:0480 413403

QUAD is a registered Trade Mark